



INFRASTRUCTURE STANDARDS AND SPECIFICATIONS



Adopted by the City Council on 10/25/2012

RESOLUTION NO 2012-19

WHEREAS, the City of Wahoo has adopted Subdivision Regulations for the development of property within the City of Wahoo, Nebraska, and that extraterritorial area within one mile of its corporate limits, and

WHEREAS, it is necessary for the City of Wahoo to establish Infrastructure Standards and Specifications to ensure conformance of subdivision plans with capital improvements programs of the city, and secure equitable handling of all subdivision plans by providing uniform procedures and standards for observance by subdividers and the Planning Commission and City Council, and

WHEREAS, JEO Consulting Group has prepared Infrastructure Standards and Specifications including survey requirements, materials and testing standards and specifications, and submittals and testing requirements, which have been reviewed and accepted by the Planning Commission and City Council.

THEREFORE BE IT RESOLVED by the Mayor and Council of the City of Wahoo that said Infrastructure Standards and Specifications, are hereby adopted and established for the City of Wahoo, effective the 25th day of October, 2012.

DATED THIS 25th of October, 2012.



City Clerk

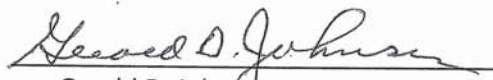

Gerald D. Johnson, Mayor



RESOLUTION NO 2012-20

WHEREAS, the City of Wahoo has adopted Subdivision Regulations for the development of property within the City of Wahoo, Nebraska, and that extraterritorial area within one mile of its corporate limits, and

WHEREAS, it is necessary for the City of Wahoo to establish a Subdivision Review Fee Schedule to ensure equitable handling of all subdivision plans by providing uniform procedures and review fees, and

WHEREAS, JEO Consulting Group has prepared a Subdivision Regulations Review Fee Schedule, which have been reviewed and accepted by the Planning Commission and City Council.

THEREFORE BE IT RESOLVED by the Mayor and Council of the City of Wahoo that said Subdivision Review Fee Schedule, is hereby adopted and established for the City of Wahoo, effective the 25th day of October, 2012.

DATED THIS 25th of October, 2012.



City Clerk

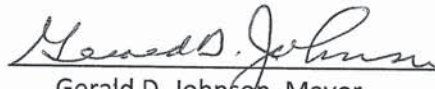

Gerald D. Johnson, Mayor

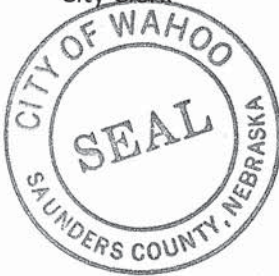

CITY OF WAHOO
SAUNDERS COUNTY, NEBRASKA

INFRASTRUCTURE
STANDARDS AND SPECIFICATIONS

JEO PROJECT NO. 090184



TABLE OF CONTENTS

1.	Subdivision Regulations Review Fee Schedule	1 Page
2.	GIS/Survey Control Network	1 Page
3.	Materials and Testing Standards and Specifications	7 Pages
4.	Submittals and Testing Requirements	2 Pages
5.	Standard Details	
	a. Storm Sewer, Sanitary Sewer, Water and Service Line Detail	
	b. Fire Hydrant Assembly Typical Section	
	c. Concrete Paving Removal and Replacement	
	d. Brick Paving Removal and Replacement	
	e. Asphalt Paving Removal and Replacement	

**SUBDIVISION REGULATIONS
REVIEW FEE SCHEDULE**

WAHOO, NEBRASKA

1. **PRELIMINARY PLAT**
 - Initial Plat Review - \$1,500
 - Revised Plat Review - \$500/Each Revised Submittal

 - ❖ Revised Plat Submittal must be within six (6) months of Initial Preliminary Plat Submittal.

2. **FINAL PLAT**
 - Initial Plat Review - \$750
 - Revised Plat Review - \$250/Each Revised Submittal

 - ❖ Revised Plat Submittal must be within six (6) months of Initial Final Plat Submittal.

3. **PLANS AND SPECIFICATIONS OF PROPOSED IMPROVEMENTS**
 - Initial Submittal Review - \$1,000 minimum up to 1% of a detailed unit price construction cost opinion (based on current unit prices) prepared by Subdividers Engineer, whichever is greater. Review fee is subject to City of Wahoo review and approval of cost opinion.
 - Revised Submittal Review - \$1,000

4. **CONSTRUCTION REVIEW**
 - 5% of construction costs. Review fee is based on the dollar amount of the construction contract between the Subdivider and independent Contractor. A detailed construction contract with construction unit prices will be furnished to the City of Wahoo by the Subdivider. If a construction contract is not entered into by Subdivider and independent Contractor the City of Wahoo will prepare a construction cost opinion for determining the review fee.

5. **CONSTRUCTION TESTING**
 - The City of Wahoo will retain the services of a certified testing laboratory to perform the testing on the project as per the Testing Specifications. The Subdivider shall pay for all testing and retesting costs. The Subdivider will be invoiced monthly for the testing costs.

**Construction cost opinion and construction contract amount shall include all infrastructure improvement costs including paving, drainage (storm sewer pipe, structures, detention cells, etc.), sanitary sewer, water, grading, erosion control, traffic control/barricading, mobilization, etc.

GIS/SURVEY CONTROL NETWORK

WAHOO, NEBRASKA

A. SURVEY REQUIREMENTS

- **Horizontal Control** – The Final Plat, and all electronic Computer Aided Drafting and Design (Cadd) deliverables for infrastructure (Paving, Drainage, Water, and Sanitary Sewer) improvements shall be tied into the City of Wahoo GIS/Survey Control Network.
- **Vertical Control** – The Final Plat, and all electronic Computer Aided Drafting and Design (Cadd) deliverables for infrastructure (Paving, Drainage, Water, and Sanitary Sewer) improvements shall reference the North American Datum of 1988 (NAVD 88), unless otherwise specified by the City of Wahoo.

MATERIALS AND TESTING STANDARDS AND SPECIFICATIONS

WAHOO, NEBRASKA

MATERIALS SPECIFICATIONS

A. CONCRETE

1. **Concrete** for streets, sidewalks, drainage structures and other structures shall be NDOR 47B – 3500 psi, as per latest NDOR specifications. Class C Fly Ash is disallowed. Type I PF cement shall be used for all concrete.
2. Full width slip form paving is the preferred method of construction for street paving. A waiver on this requirement maybe granted by the City if requested by the subdivider.

B. STORM SEWER

1. **Storm Sewer Pipe** shall be Class III reinforced concrete pipe (RCP).
2. **Inlets** shall be NDOR type curb inlets. Inlets shall be cast in place concrete.
3. **Drainage Structures** shall be NDOR type manholes, junction boxes, collars, pipe taps, etc.

C. WATER

1. **Water Main Pipe** shall be Polyvinyl Chloride (PVC) Class 150 DR18 meeting all of the requirements of AWWA C-900 (latest revision) with push-on gasketed bell ends, minimum size 6 inch. Minimum cover of 5'-6".
2. **Fittings** shall be Griffin or Tyler and shall meet the requirements of AWWA C153/111 or C110/153 mechanical joint and cement lined. All fittings shall be polywrapped and shall have poured in place thrust blocks.
3. **Couplings** will be Ductile Iron with stainless steel bolts and nuts. The working pressure shall be 150 psi.
4. **Valves** shall be Mueller Co. or American Flow Control and shall conform to ANSI/AWWA C509. Direction of opening: Counterclockwise
5. **Valve Boxes** shall have a screw type extension sleeve. The cover shall have the word "WATER" cast thereon.
6. **Fire Hydrants** shall be American Flow Control B-84-B or Mueller Super Centurion 250 and shall conform to ANSI/AWWA C502. The fire hydrant shall have a 6" inlet connection, 5-1/4" main valve opening, one 4-1/2 inch pumper nozzle and two 2-1/2" hose nozzles with a minimum 6'-0" bury. Direction of opening: Counterclockwise
7. **Trace Wire** will be installed with all water main. The trace wire will be No. 12 AWG solid copper with type THHN insulation. Valvco tracer wire access boxes will be installed at approximately one block intervals along the rout of the water main which includes fire hydrant locations.
8. **Water Service Line Pipe** will be polyethylene (PE) plastic pipe (SIDR-PR) conforming to ASTM D2239 and AWWA C901, SIDR7. Minimum size 3/4" and minimum cover of 5'-6".
9. The water service line will be connected to the water main with a saddle (Smith Blair Model 317) and a corporation with a swivel 1/8 bend. The working pressure

shall be 150 psi. The water service line will terminate with a curb stop with a 42 inch stationary rod and an Arch pattern extendable type curb stop box with a minimum inside diameter of 1-1/2 inches and a pentagon bolt plug style lid. The curb stop box will be located on the street right of way line/property line.

D. SANITARY SEWER

1. **Sewer Main Pipe** shall be Polyvinyl Chloride (PVC) solid wall pipe conforming to ASTM D3034, ~~SDR26~~ SDR35 (Amended 12/11/2014) with bell and spigot type joint with a rubber gasket, minimum size 8 inch.
2. **Manholes** will be precast concrete in accordance with ASTM C478 with resilient connectors complying with ASTM C921. The base shall be precast or cast in place. Joints will be sealed with a flexible butyl rubber joint sealant. Exterior bituminous damp proofing of the manhole sections is required. Manhole steps shall be ½ inch grade 60 reinforcing steel encapsulated in molded copolymer polypropylene. The manhole cover will be a Deeter Foundry 1030 Ring and Cover.
3. **Sanitary Sewer Service Line Pipe** will be Polyvinyl Chloride (PVC) solid wall pipe SDR 26 with bell and spigot type joint with a rubber gasket minimum size 4 inch. The sanitary sewer service line will terminate with a plug at the street right of way line/property line.
4. **Sanitary Sewer Service Wye** will be compatible with the main line sewer material.

E. DETECTABLE WARNING PANELS

1. If sidewalk is constructed as part of the project at all curb ramps, detectable warning panels will be installed. The panels shall be Armor Tile Cast in Place System, Color Black.

F. STREET LIGHTING

1. All street lighting will be approved by Wahoo Utilities.

G. SUBGRADE, TRENCH AND GRADING

1. All subgrade, trench and grading compaction will meet the requirements of the Geotechnical Report.

- H. All sanitary sewer and water improvements will meet the requirements of the Recommended Standards for Water Works, latest edition (aka 10 States Standards) by Great Lakes. Upper Mississippi River Board of State Public Health and Environmental Managers.

TESTING SPECIFICATIONS

1. GRADING/FILL TESTING:

A. Frequency of Tests:

1. 1 test for each lift of 0 to 1 feet in depth per 100' x 100' area.

2. TRENCH TESTING:

A. Water Piping: Frequency of Tests:

1. Under Paving, Slabs-on-Grade and Similar Construction:
 - a. 1 test per 150 linear feet of main line. Test at random depths.
 - b. 1 test of each service line. Test at random depths.
2. Nonpaved Area:
 - a. 1 test per 300 linear feet of main line. Test at random depths.
 - b. 1 test of each service line. Test at random depths.

B. Sanitary Sewer Piping: Frequency of Tests:

1. Under Paving, Slabs-on-Grade and Similar Construction:
 - a. 2 tests per 150 linear feet of main line, test lower portion and test upper portion of trench.
 - b. 1 test of each service line. Test at random depths.
2. Nonpaved Area:
 - a. 2 tests per 300 linear feet of main line, test lower portion and test upper portion of trench.
 - b. 1 test of each service line. Test at random depths.
3. 1 test at each manhole location. Test at random depths.

C. Storm Drainage Piping: Frequency of Tests:

1. Under Paving, Slabs-on-Grade and Similar Construction:
 - a. 1 test per 150 linear feet of main line. Test at random depths.
2. Nonpaved Area:
 - a. 1 test per 300 linear feet of main line. Test at random depths.

3. SUBGRADE TESTING:

A. Frequency of Tests: 1 test per 100 to 150 linear feet of subgrade.

4. CONCRETE TESTING:

- A. Compressive Strength Test Samples: ASTM C 39. For each test, mold and cure 3 concrete test cylinders. A set of 3 test cylinders shall be collected for every 200 cubic yard or fractional part thereof for each class of concrete placed in a day. At least one set of cylinders is required for each day concrete placement takes place for paving, sidewalk and cast in place structures.
1. One additional cylinder may be required for a break prior to 7 days.
 2. Take 1 additional test cylinder during cold weather concreting, as defined by the Nebraska Department of Roads Standard Specifications Latest Edition and cured on the job site under the same conditions as the concrete it represents.
 3. If the compressive strength is less than specified, the concrete paving will be subject to a pay deduction or rejection as defined by the Nebraska Department of Roads Standard Specifications Latest Edition.
- B. Slump Test - Perform 1 slump test for each set of test cylinders taken.
1. If the concrete mixture is excessively wet causing segregation, excessive bleeding, or any other undesirable condition, the concrete shall be rejected.
 2. If the slump is outside the allowable limits as defined by the Nebraska Department of Roads Standard Specifications Latest Edition, the load of concrete shall be rejected.
- C. Air Test - Perform 1 air content test for each set of test cylinders taken.
1. If the air content is less than the minimum specified, only one addition of air-entraining admixtures is allowed.
 2. If the air content is outside the allowable limits as defined by the Nebraska Department of Roads Standard Specifications Latest Edition, the load of concrete shall be rejected.
- D. Pavement Thickness Test:
1. Obtain a core sample of concrete paving at 150 foot intervals of the entire length of paving.
 2. If the pavement thickness is less than specified the pavement will be subject to a pay deduction or rejection as defined by the Nebraska Department of Roads Standard Specifications Latest Edition.

5. FLUSHING

A. Water Main:

1. Procedure:

- a. Obtain approval of Wahoo Utilities to flush new water main and to discharge chlorinated water into storm sewer or natural water way.
- b. Use flushing methods which prevent damage to private and public property.
- c. Hydrants may be used for flushing.
- d. Minimum Flushing Velocity: 2.5 feet per second (fps).
- e. Flush 5 times the volume of the line or as directed by Wahoo Utilities.
- f. Ascertain that heavily chlorinated water has been removed from waterline.
- g. Chlorine concentration should be no higher than that generally maintained in the system or less than 1 mg/L.

6. BACTERIOLOGICAL TESTING:

A. Water Samples:

1. Procedure:

- a. After final flushing and before new waterline is placed in service, fill line with potable water.
- b. Install corporation stop on waterline with copper tube gooseneck assembly.
- c. Collect 2 consecutive sets of samples at least 24 hours apart
- d. Location of Samples:
 - (1) 1 set at end of each test section.
 - (2) 1 set for every 1,200 feet.
 - (3) 1 set from each branch.
- e. Collect samples in sterile bottles treated with sodium thiosulfate.
- f. Do not take samples from hose or fire hydrant.

2. Submit water samples to state regulatory agency laboratory or certified testing laboratory for bacteriological analysis.

3. Bacteriological Test Failure:

- a. Repeat flushing and disinfection procedures.
- b. Use continuous-feed method for disinfection.
- c. Repeat bacteriological sampling and testing.
- d. Contractor may be invoiced for the water used to flush if more than 2 sets of samples fail (at the discretion of the City).

7. PRESSURE TESTING:

A. Water Main:

1. Perform a Hydrostatic Test of all water main piping.
2. Pressure test piping and appurtenances in accordance with AWWA C 600 or C 605.
3. Test individual sections between valves.
4. Test Pressure: 150 psi
5. Minimum Test Period: 2 hours
6. Allowable Leakage:
 - a. PVC Pipe: Allowable leakage formula.
 $Q = LD \times \sqrt{P}$ divided by 148,000 where
Q = Quantity of makeup water, in gallons per hour
L = Length of pipe section being tested, in feet
D = Nominal diameter of pipe in inches
P = Average test pressure during the hydrostatic test, in pounds per square inch (gauge)
 - b. Ductile Iron Pipe: Allowable leakage formula.
 $L = SD \times \sqrt{P}$ divided by 148,000 where
L = Testing allowance (makeup water), in gallons per hour
S = Length of pipe being tested in feet
D = Nominal diameter of pipe in inches
P = Average test pressure during the hydrostatic test, in pounds per square inch (gauge)

B. Sewer Main:

1. Perform a Low Pressure Air Test of all sanitary sewer main piping.
 - a. Test in accordance with ASTM F 1417.
 - b. Test individual section(s) between pneumatic plugs.
 - c. Test pressure of 3.5 psi at start of test.
 - d. More than 1.0 psi pressure drop during test time indicates failed test.
2. Perform an alignment and deflection test of all sanitary sewer main piping.
 - a. Provide alignment and deflection test 30 days after backfilling trench.
 - b. Use rigid ball or mandrel having not less than 95 percent of base inside diameter or average inside diameter of pipe depending on which is specified in ASTM to which the pipe is manufactured.
3. Perform a TV Inspection of all of the sanitary sewer main piping.
 - a. DVD Video tape.
 - b. Written log of location of:
 - (1) Service wyes or tees as measured from manhole.
 - (2) Location of defects in pipe or joints.
 - (3) Location of debris in pipe.
 - (4) Location of any sags.

(5) Other notable items in pipe.

C. Sewer Force Main:

1. Pressure test piping and appurtenances in accordance with AWWA C 600.
2. Test individual section(s) between valves.
3. Test Pressure: 150 psi
4. Minimum Test Period: 2 hours
5. Allowable Leakage:
 - (1) PVC Pipe: Allowable Leakage Formula
 $L = ND \times \sqrt{P}$ divided by 7,400 where
L = Allowable leakage in gallons per hour
N = Number of joints in length of pipe being tested
D = Nominal diameter of pipe in inches
P = Average test pressure in pound per square inch (psi)
 - (2) Ductile Iron Pipe: Allowable Leakage Formula
 $L = SD \times \sqrt{P}$ divided by 133,200 where
L = Allowable leakage in gallons per hour
S = Length of pipe being tested in feet
D = Nominal diameter of pipe in inches
P = Average test pressure in pound per square inch (psi)

8. TESTING DOCUMENTATION AND FAILED TESTS:

- A. The independent testing laboratory shall document the location, date and test results of all testing on the project. Tests and test locations that fail will be retested until the test result meets the specifications. A copy of all test results will be furnished to the City Administrator.
- B. The independent testing laboratory shall document placed concrete items. Documentation will include; concrete item tested, type of test sample taken, test results (slump, air content, air temperature, etc.), date, test cylinder number and location of sample collected.
- C. Additional Tests: The testing laboratory shall make additional tests of concrete, when test results indicate that slump, air entrainment, compressive strength, pavement thickness or other requirements have not been met.

**SUBMITTALS AND TESTING REQUIREMENTS
WAHOO, NEBRASKA**

- A. SUBDIVIDER TO SUBMIT TO THE CITY ADMINISTRATOR THREE (3) PAPER COPIES AND AN ELECTRONIC COPY (PDF OF EACH ITEM) COMBINED ON ONE (1) CD OF THE FOLLOWING FOR REVIEW AND APPROVAL BY THE CITY OF WAHOO :
- Final Plans and Specifications of Improvements, prepared by an Engineer licensed to practice in the State of Nebraska
 - Final Drainage Report, prepared by an Engineer licensed to practice in the State of Nebraska
 - Traffic Study (If Required) prepared by an Engineer licensed to practice in the State of Nebraska
 - Landscape/Tree Plan (If Required)
 - Storm Water Pollution Prevention Plan (SWPPP) prepared by an Engineer licensed to practice in the State of Nebraska
 - Geotechnical Report, prepared by a Geotechnical Engineer licensed to practice in the State of Nebraska
 - Unit Price Cost Opinion of Improvements, prepared by an Engineer licensed to practice in the State of Nebraska
 - Subdivision Agreement
- B. PRIOR TO THE START OF CONSTRUCTION ACTIVITIES SUBDIVIDER TO SUBMIT TO THE CITY ADMINISTRATOR THREE (3) PAPER COPIES AND AN ELECTRONIC COPY (PDF OF EACH ITEM) COMBINED ON ONE (1) CD OF THE FOLLOWING FOR REVIEW AND APPROVAL BY THE CITY OF WAHOO:
- Shop Drawings of Materials and Equipment to be incorporated into Project.
 - Executed Contract with Construction Company.
 - Approval Letter of Improvements from:
 - Nebraska Department of Health and Human Services
 - Nebraska Department of Environmental Quality
 - Permits
 - NPDES Permit for Storm Water Discharges from Construction Sites
 - NDOR (If Applicable)
 - Other Permits (If Applicable)
- C. THE CITY OF WAHOO WILL RETAIN THE SERVICES OF A CERTIFIED TESTING LABORATORY TO PROVIDE THE FOLLOWING TESTING SERVICES DURING CONSTRUCTION. THE SUBDIVIDER SHALL PAY FOR ALL TESTING AND RETESTING COSTS. THE CITY OF WAHOO WILL SUBMIT A COPY OF THE EXECUTED AGREEMENT FOR THE SERVICES TO THE SUBDIVIDER PRIOR TO THE START OF ANY CONSTRUCTION ACTIVITIES
- Grading/Fill Testing

- Trench Testing
- Subgrade Testing
- Concrete Testing
 - Air
 - Slump
 - Strength
- Pavement Thickness Testing
- Sanitary Sewer Main Testing
 - Low Pressure Air Test
 - Alignment and Deflection Test
 - TV Inspection
- Water Main Testing
 - Bacteriological Samples
 - Hydrostatic Pressure Test
- Storm Water Pollution Prevention Plan (SWPPP) Monitoring
 - Storm Water Construction Site Inspection Report by a certified erosion and sediment control inspector
 - Erosion and Sediment Control Maintenance Report by a certified erosion and sediment control inspector
- ❖ Testing Data to be submitted to City Administrator as each element of project is completed

D. POST CONSTRUCTION REVIEW:

- Subdivider to submit to the City Administrator three (3) paper copies and an electronic copy (PDF) on a CD the following:
 1. As Built drawings of the improvements by the Engineer who prepared the plans and specifications.
 2. Final statement of costs prepared by the Engineer who prepared the plans and specifications.
 3. Request in writing by the Subdivider for the City of Wahoo to accept the improvements.

E. CONSTRUCTION REVIEW BY CITY STAFF AND OR CITY ENGINEER:

- Develop a Scope of Services for Construction Review
- Review Testing Data
- Part-time On-Site Construction Observation
- Monthly Progress Report to City Administrator
- Recommendation of Acceptance

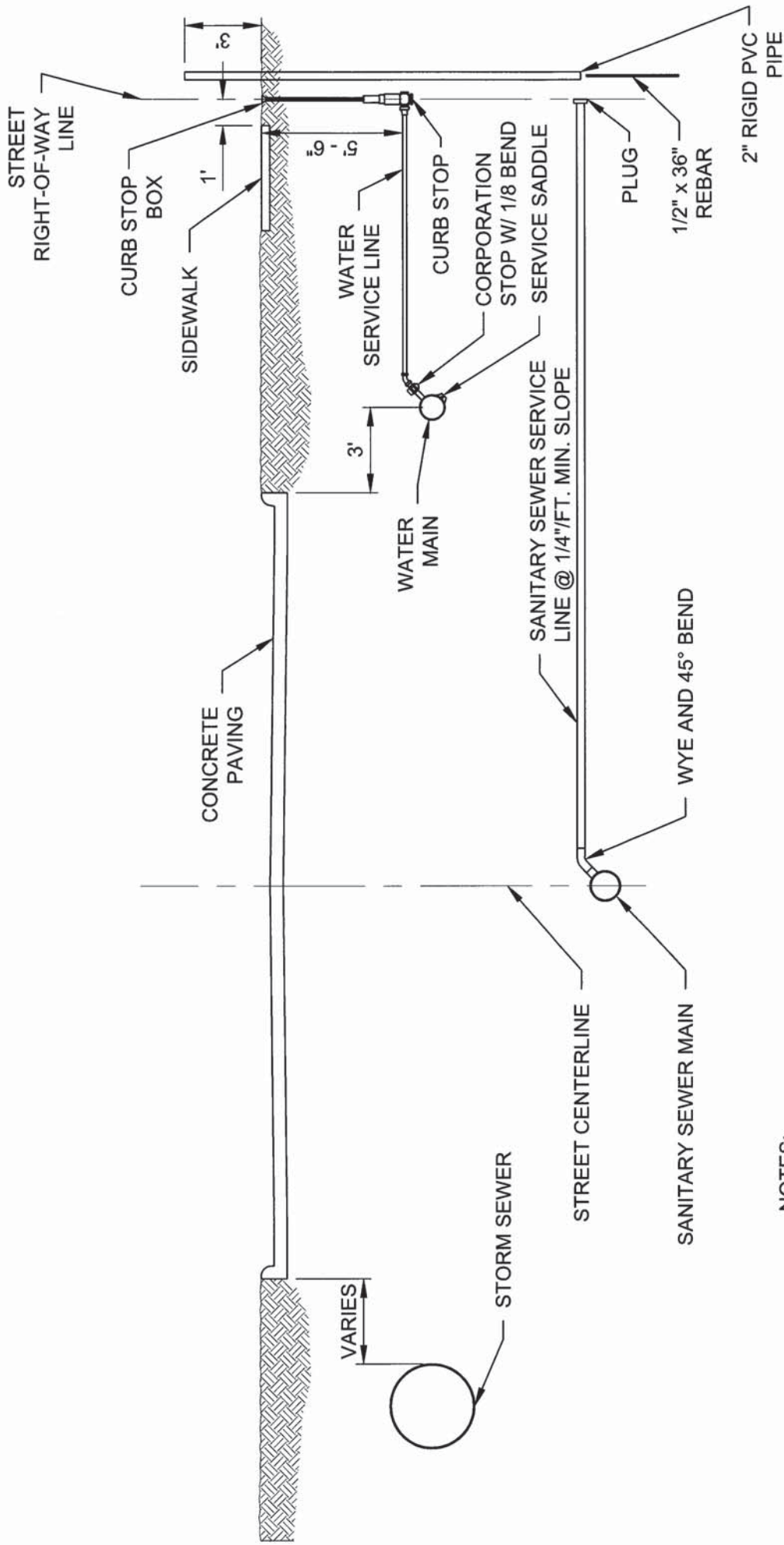

NOTES:

1. WATER SERVICE LINE CURB STOP BOX TO BE LOCATED ON STREET RIGHT-OF-WAY LINE
2. SANITARY SEWER SERVICE LINE TO TERMINATE AT STREET RIGHT-OF-WAY LINE
3. AFTER CONSTRUCTION "HOME OWNER" IS RESPONSIBLE FOR SANITARY SEWER SERVICE LINE.

STORM SEWER, SANITARY SEWER, WATER AND SERVICE LINE DETAIL



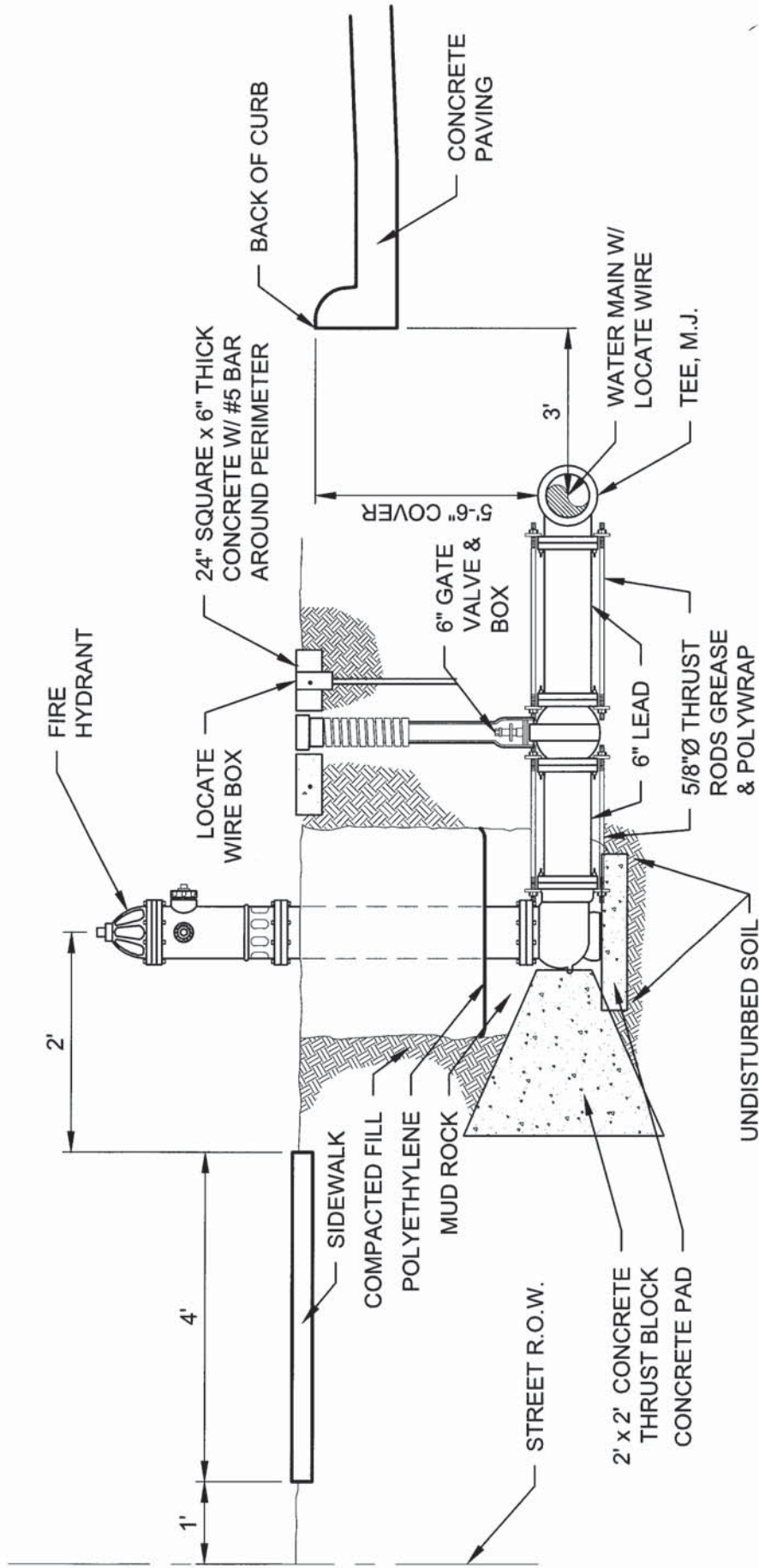

NOTES:

1. HYDRANT ASSEMBLY TO INCLUDE MEGALUG PVC JOINT RESTRAINT, THRUST RODS, PIPING AND GATE VALVE.
2. ALL FITTINGS TO BE MECHANICAL JOINT, WITH MEGALUG PVC JOINT RESTRAINT
3. ALL CONNECTIONS TO FIRE HYDRANT, VALVE, AND TEE TO HAVE MEGALUG PVC JOINT RESTRAINT.
4. THRUST RODS AND APPURTENANCES SHALL BE STAINLESS STEEL OR CORTEN STEEL

FIRE HYDRANT ASSEMBLY TYPICAL SECTION

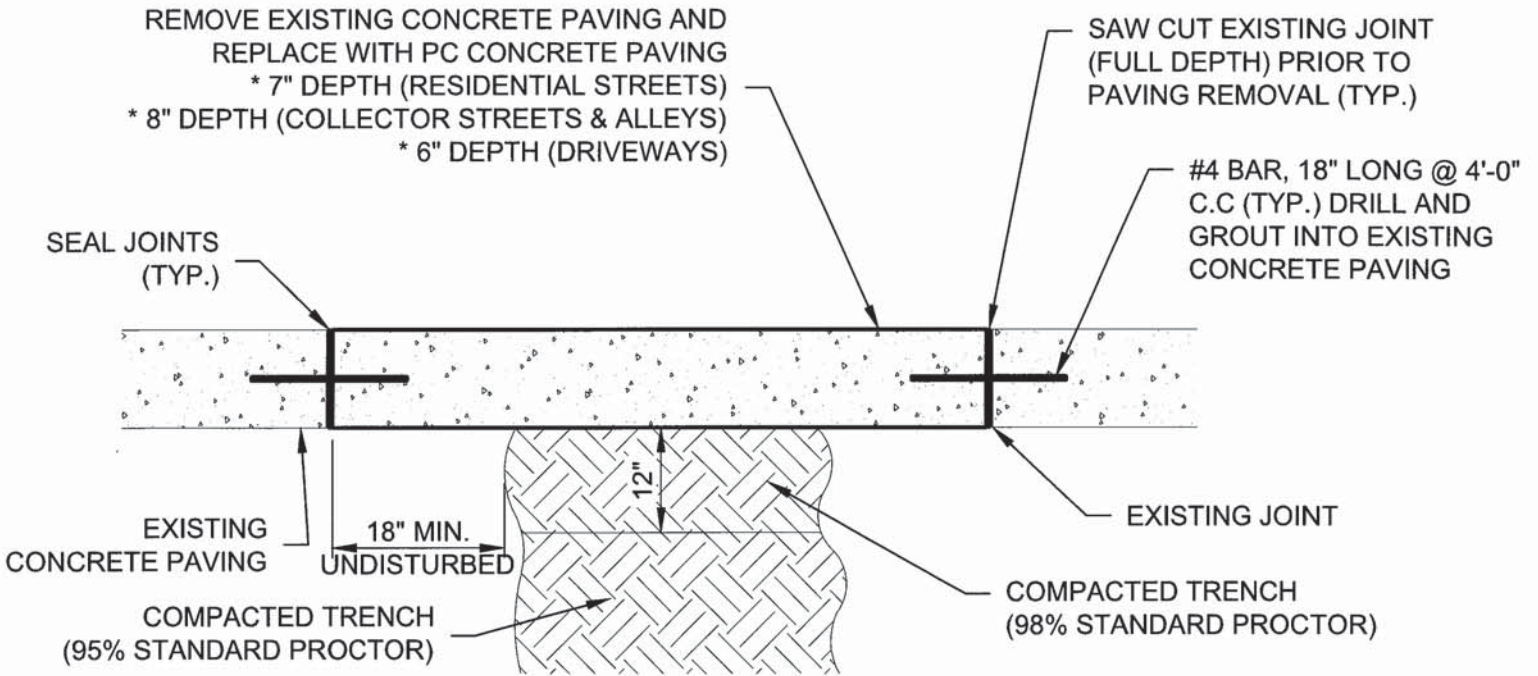

NOTE:

1. ALL PAVING REMOVAL SHALL BE TO EXISTING JOINTS.
2. COMPACT TRENCH IN LIFTS (12" MAX DEPTH)
3. CONCRETE PAVING - NDOR 47B 3500 PSI
4. BURLAP FINISH CONCRETE
5. APPLY CURING COMPOUND (NDOR) OR WET BURLAP AFTER FINISHING CONCRETE
6. PERIMETER JOINT SHALL BE TOOLED
7. SAW JOINTS T/4 (MATCH EXISTING JOINT PATTERN)
8. SEAL JOINTS WITH HOT Poured JOINT SEALANT (NDOR) OR SONOLASTIC SL1 SEALANT (GRAY)

CONCRETE PAVING REMOVAL & REPLACEMENT

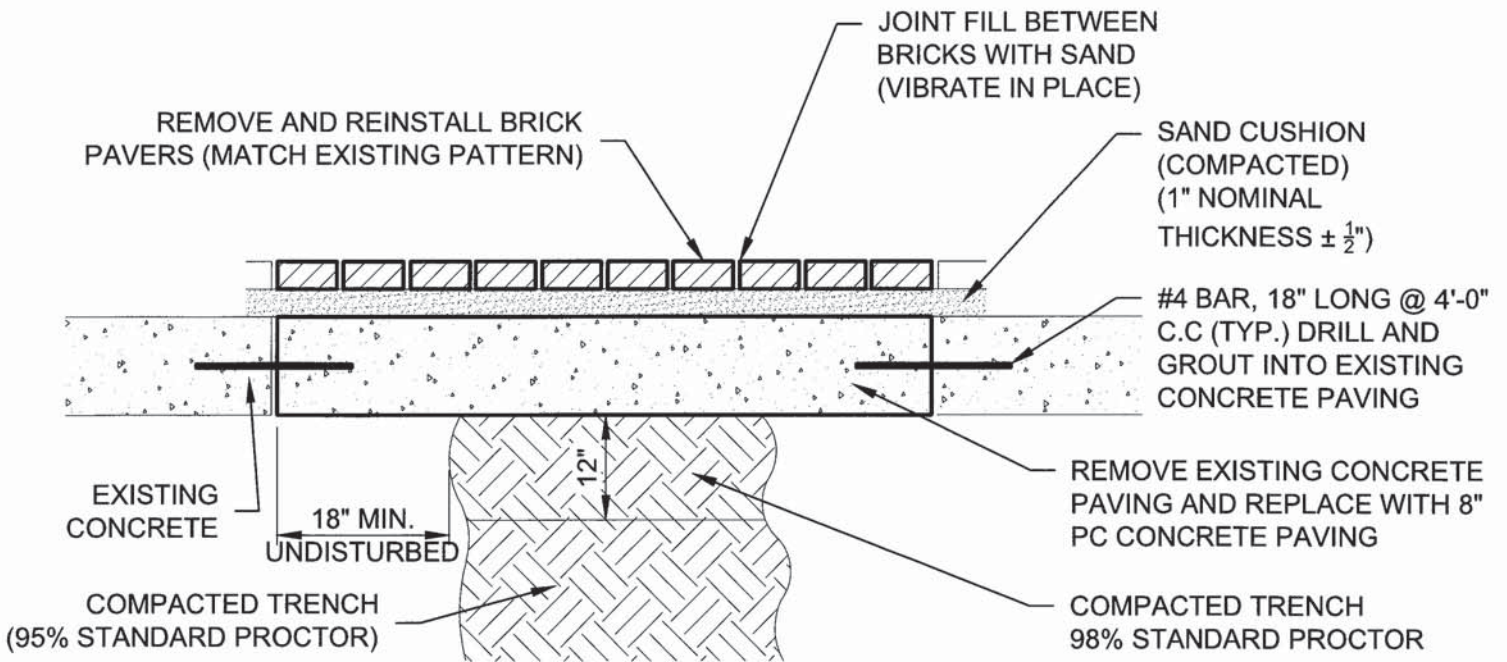

NOTE:

1. COMPACT TRENCH IN LIFTS (12" MAX DEPTH)
2. CONCRETE PAVING - NDOR 47B 3500 PSI
3. APPLY CURING COMPOUND (NDOR) OR WET BURLAP AFTER FINISHING CONCRETE

BRICK PAVING REMOVAL AND REPLACEMENT

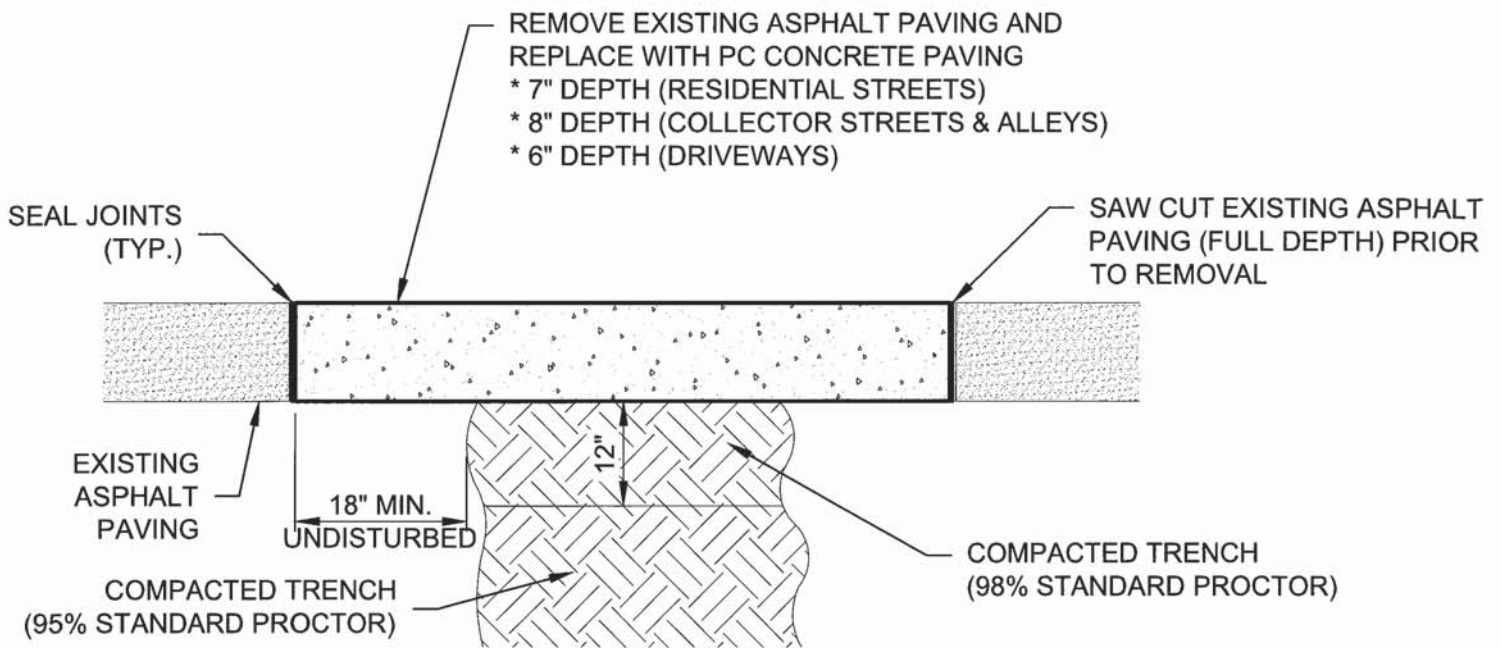

NOTE:

1. COMPACT TRENCH IN LIFTS (12" MAX DEPTH)
2. CONCRETE PAVING - NDOR 47B 3500 PSI
3. BURLAP FINISH CONCRETE
4. APPLY CURING COMPOUND (NDOR) OR WET BURLAP AFTER FINISHING CONCRETE
5. PERIMETER JOINT SHALL BE TOOLED
6. SAWED JOINTS T/4 (PANEL LENGTH TO WIDTH RATIO SHALL BE 125% MAX)
7. SEAL JOINTS WITH HOT POURED JOINT SEALANT (NDOR) OR SONOLASTIC SL1 SEALANT (GRAY)

ASPHALT PAVING REMOVAL & REPLACEMENT

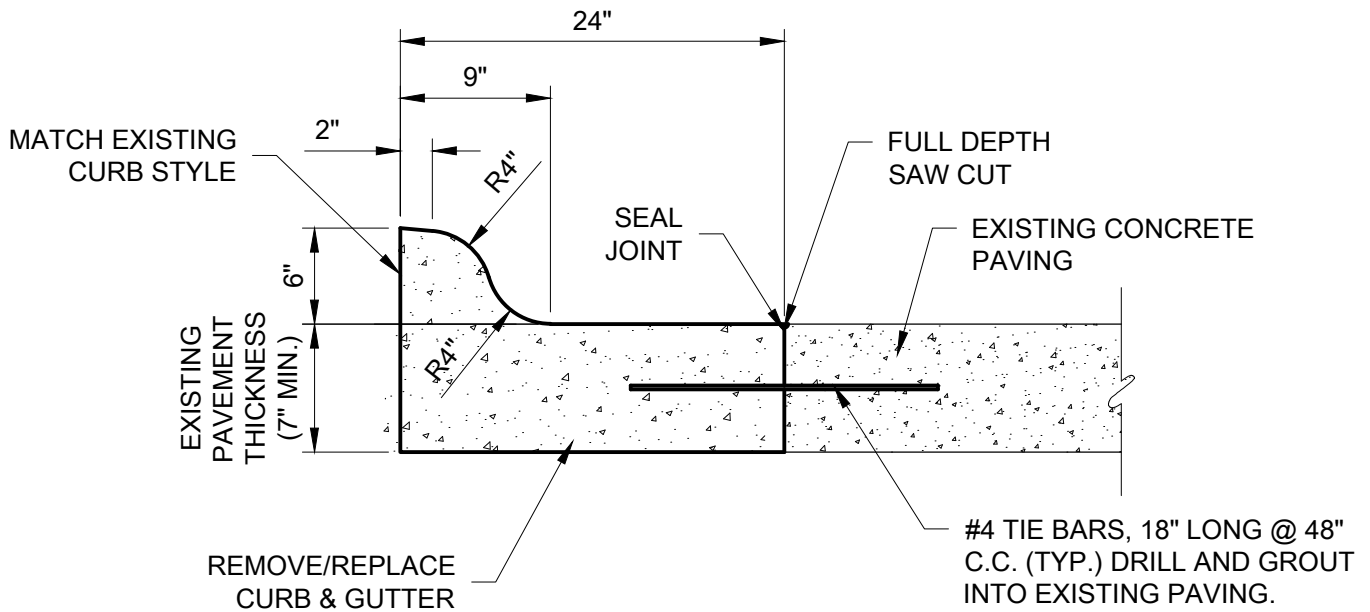

NOTES:

1. CONCRETE PAVING - NDOR 47B 3500 PSI
2. CONSTRUCT CURB TO MATCH EXISTING ADJACENT CURB STYLE
3. BURLAP FINISH CONCRETE
4. APPLY CURING COMPOUND (NDOR) OR WET BURLAP AFTER FINISHING CONCRETE
5. PERIMETER JOINT SHALL BE TOOLED
6. SAW JOINTS T/4 (MATCH EXISTING JOINT PATTERN)
7. SEAL JOINTS WITH HOT POURED JOINT SEALANT (NDOR) OR SONOLASTIC SL1 SEALANT (GRAY).

CURB & GUTTER REPLACEMENT



JED CONSULTING GROUP INC.

800.723.8567

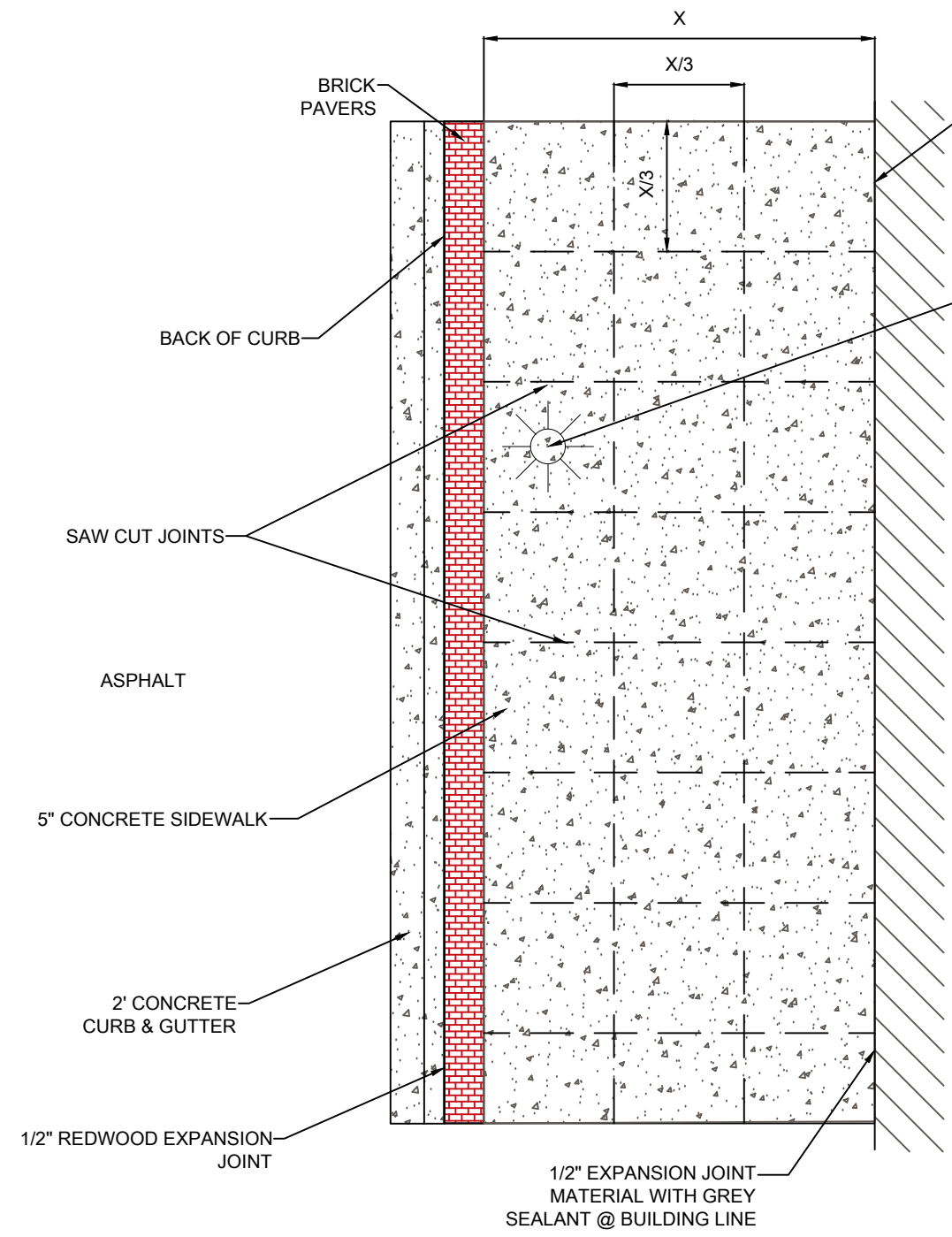

TYPICAL JOINT PATTERN

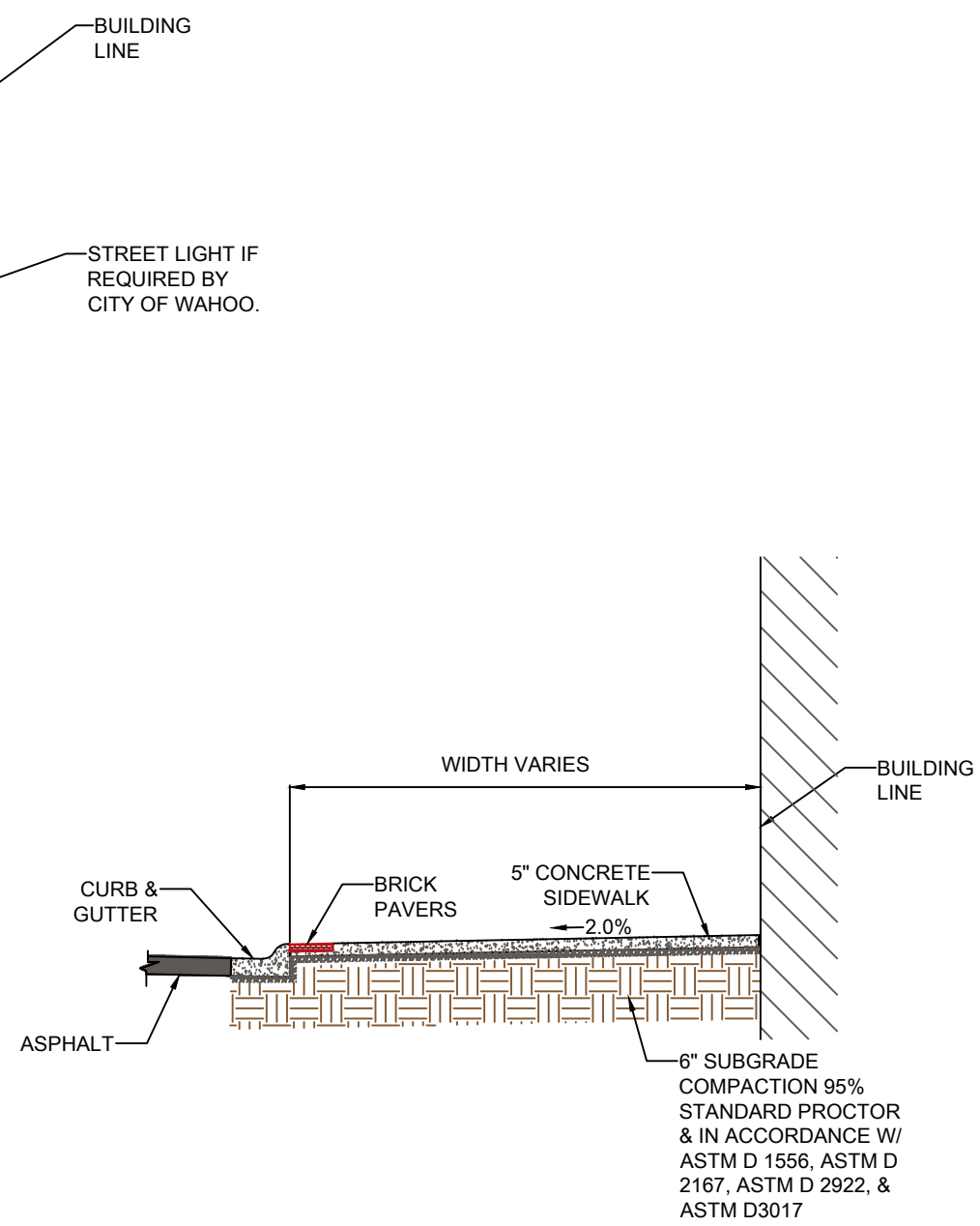

TYPICAL SIDEWALK CROSS SECTION

NOTE:

1. ALL SIDEWALKS SHALL HAVE A BROOM FINISH.
2. ALL CONCRETE SHALL BE NDOR 47B 3,500.
3. ALL SIDEWALKS MUST HAVE A 5' WIDE SECTION ADJACENT TO BUILDING WITH A MAX OF 2.0% CROSS SLOPE.

WAHOO DOWNTOWN SIDEWALK TYPICAL

2016
DOWNTOWN SIDEWALK
WAHOO, NEBRASKA

TYPICAL SIDEWALK



PROJECT NO.	Project No.
DATE	9/1/2016
DRAWN BY	Drawn By
FILE NAME	Wahoo Downtown Typical.dwg
FIELD BOOK	Field Book
FIELD CREW	Field Crew
SURVEY FILE NO.	Survey File #
PLAN IN HAND	PIH INI
INITIALS	PIH Date
70 PERCENT REVIEW	70% INI
INITIALS	70% DATE
95 PERCENT REVIEW	95% INI
INITIALS	95% DATE
REVISIONS	

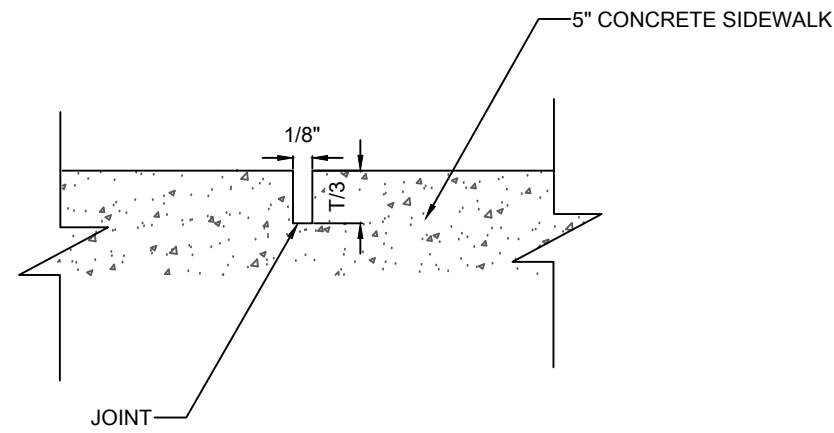

SAW CUT JOINT

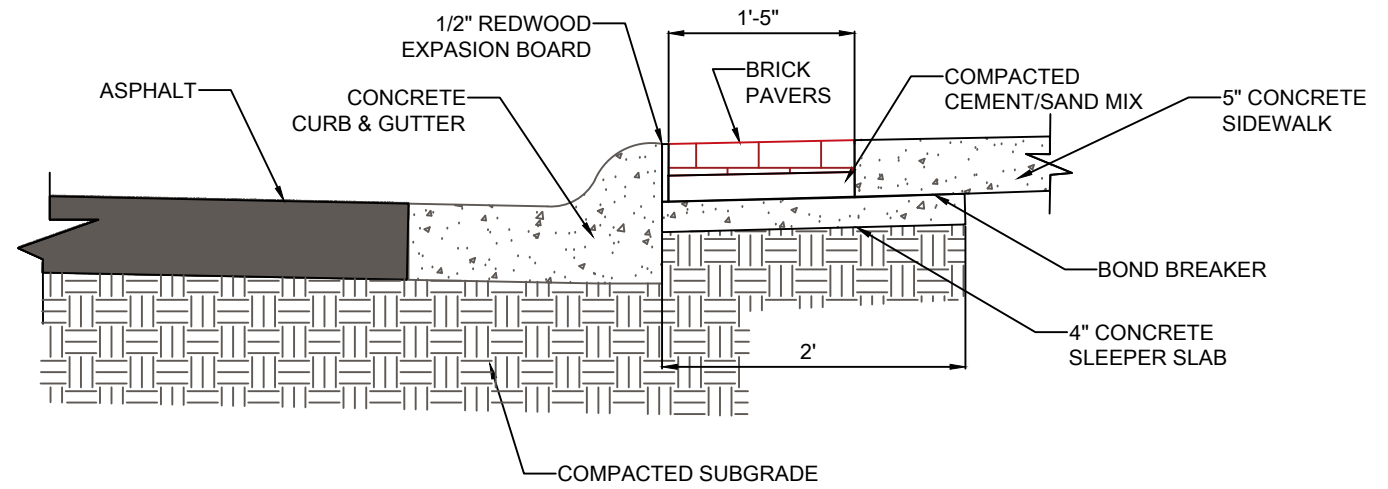

BRICK PAVER

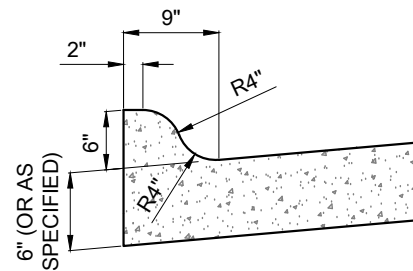

CURB DETAIL

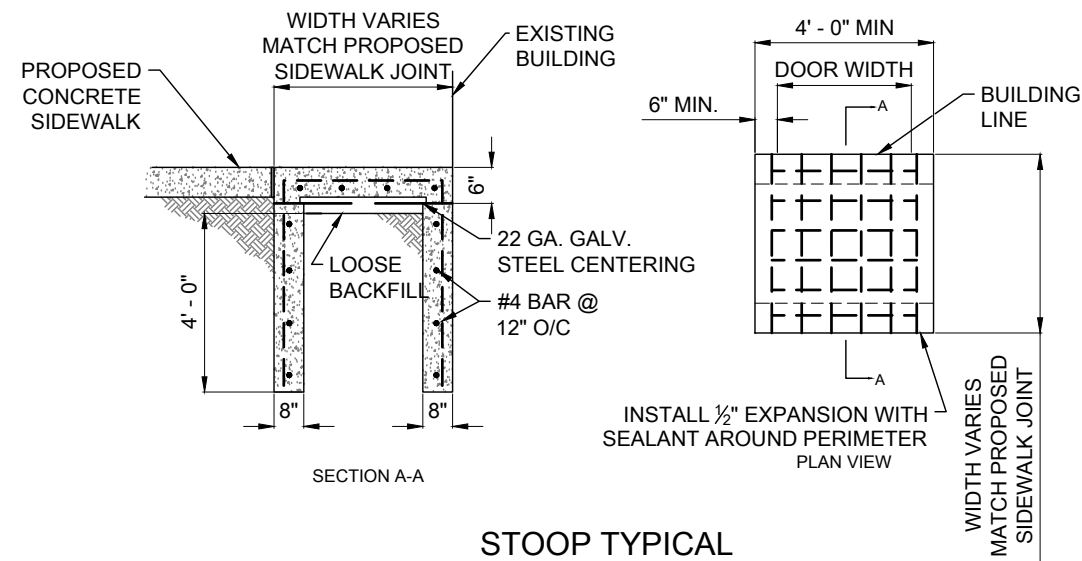

STOOP TYPICAL

- NOTE:**
1. STRUCTURAL STOOP REQUIRED IF DOOR AT ENTRANCE TO BUILDING OPENS TO STREET.

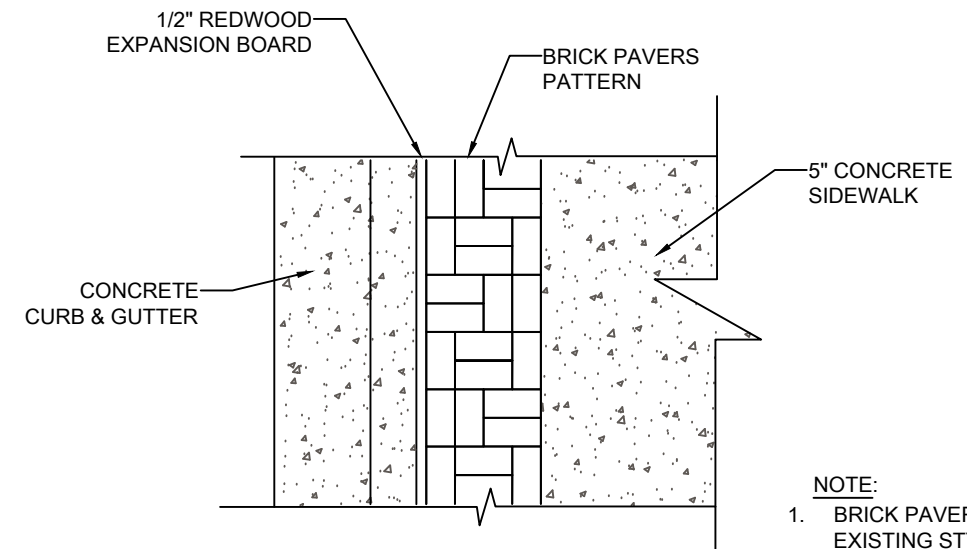

REPEATING BRICK PAVER PATTERN

- NOTE:**
1. BRICK PAVERS TO MATCH EXISTING STYLE AND COLOR.

2016
DOWNTOWN SIDEWALK
WAHOO, NEBRASKA

TYPICAL SIDEWALK



PROJECT NO.	Project No.
DATE	8/25/2016
DRAWN BY	Drawn By
FILE NAME	Wahoo Downtown Typical.dwg
FIELD BOOK	Field Book
FIELD CREW	Field Crew
SURVEY FILE NO.	Survey File #
PLAN IN HAND	PHI INI
INITIALS	PHI DATE
70 PERCENT REVIEW	70% INI
INITIALS	70% DATE
95 PERCENT REVIEW	95% INI
INITIALS	95% DATE
REVISIONS	